

42" CLASS (42.0" DIAGONAL)	42LC50C
37" CLASS (37.0" DIAGONAL)	37LC50C 37LC50CB
32" CLASS (31.5" DIAGONAL)	32LC50C 32LC50CB 32LC50CS

LCD Widescreen HDTV with HD-PPV Capability



NATIVE DISPLAY RESOLUTION
1366 x 768

MPEG-2/MPEG-4 H.264
DECODING

NEW! DYNAMIC POWER SAVINGS

HD VOD PPV ENCRYPTION
Integrated Pro:Idiom®

BUILT-IN TUNER
ATSC/NTSC/QAM Clear

IMPROVED! DYNAMIC CONTRAST RATIO
12,000:1

LG's EXCLUSIVE XD ENGINE®

SPLIT SCREEN
Using optional auto-sensing
remote jack pack (RJP)

AUTO-SENSING REMOTE JACK PACK
(RJP) COMPATIBLE

NEW! OPTIONAL SECURITY SCREWS INCLUDED

NEW! CUSTOMIZABLE CLOSED CAPTIONS

2 HDMI™ INPUTS WITH HDCP

2-YEAR LIMITED WARRANTY
parts/labor

NOTE: IP-Cast™ ready with integrated card slot using LG's IP card solution for Digital Signage applications (sold separately). Contact DSinfo@LGcommercial.com for more information. If using DIRECTV's™ Free-To-Guest, an additional card may be required.

XD ENGINE

SHARPER
BRIGHTER
CLEARER

ULTRA CONTRAST

AT A BLAZINGLY FAST 370 MILLION PIXELS PER SECOND, THE PROCESSOR USES A HISTOGRAM ANALYZATION TOOL TO CLARIFY THE IMAGE DATA ACCORDING TO SIGNAL BRIGHTNESS LEVELS.

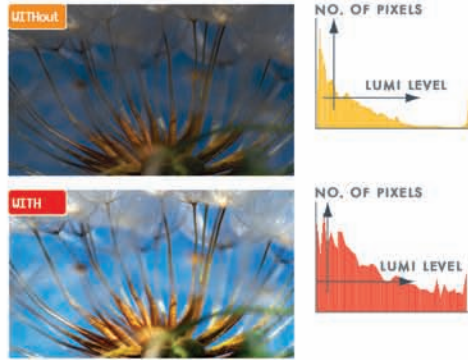

Dramatization

DYNAMIC BLACK STRETCH

THE MINIMUM BLACK LEVEL OF AN IMAGE IS AUTOMATICALLY DETECTED AND ADJUSTED ACCORDING TO BRIGHTNESS.

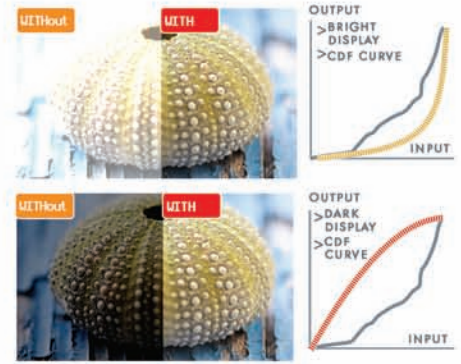

Dramatization

OPTIONS

AVAILABLE COLORS

42LC50C (high gloss black)
37LC50C (high gloss black)
32LC50C (high gloss black)



37LC50CB (matte black)
32LC50CB (matte black)



32LC50CS (silver)



FREE-TO-GUEST CARD



HCS1410
FREE-TO-GUEST CARD

The optional HCS1410 card can be inserted into the MPI slot on the back of the LC50 series. It is to be used for properties without a Pay-Per-View system but still want to receive Pro:Idiom™ locked free-to-guest high-definition channels.

CLONING PROGRAMMER REMOTE



LT2002
QUICKSET II "CLONE"

The optional LT2002 allows for custom setup and programming information to be quickly copied from a "master" LG or Zenith brand LCD, Plasma, or CRT TV (with the MPI™ input) into an unlimited number of identical models. This saves the installers hours of time duplicating the hotel TV settings, such as minimum volume, maximum volume, start up channel, channel mapping, etc.

POWER SAVING LEVELS

By selecting lower levels of backlight settings, a reduction in power consumption is achieved resulting in energy savings and lower costs.

42LC50C in Vivid Mode

BACKLIGHT SETTING VALUE	BRIGHTNESS (cd/m ²)	*POWER CONSUMPTION (Watts)
Level 100	302 cd/m ²	215 Watts
90	93%**	92%**
80	84%	85%
70	73%	78%
60	61%	72%
50	50%	66%
40	41%	60%
30	34%	54%
20	27%	47%
10	22%	40%
1	18%	34%

37LC50C/CB in Vivid Mode

BACKLIGHT SETTING VALUE	BRIGHTNESS (cd/m ²)	*POWER CONSUMPTION (Watts)
Level 100	306 cd/m ²	164 Watts
90	86%**	89%**
80	78%	84%
70	72%	78%
60	65%	73%
50	60%	68%
40	53%	62%
30	45%	57%
20	39%	51%
10	32%	45%
1	25%	40%

32LC50C/CB/CS in Vivid Mode

BACKLIGHT SETTING VALUE	BRIGHTNESS (cd/m ²)	*POWER CONSUMPTION (Watts)
Level 100	282 cd/m ²	130 Watts
90	85%**	92%**
80	76%	86%
70	66%	81%
60	56%	76%
50	49%	70%
40	41%	65%
30	34%	62%
20	28%	56%
10	22%	52%
1	18%	46%

* Power consumption was measured using IEC62087 dynamic broadcast - content video signal
** All percentages listed are percentages based off of level 100

CLEAR SCREEN

USING THE NOISE FILTER INSIDE THE XD ENGINE CHIP, THE IMAGE IS ANALYZED FOR TEMPORAL AND SPATIAL INFORMATION TO REDUCE MPEG NOISE.

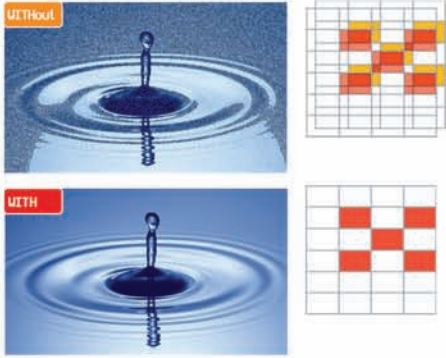

Dramatization

ADVANCED VIVID COLOR

COLORS THAT ARE SENSITIVE TO THE HUMAN EYE ARE OPTIMIZED TO THE NEAREST TRUE COLOR BY THE SELECTIVE COLOR CONTROL.

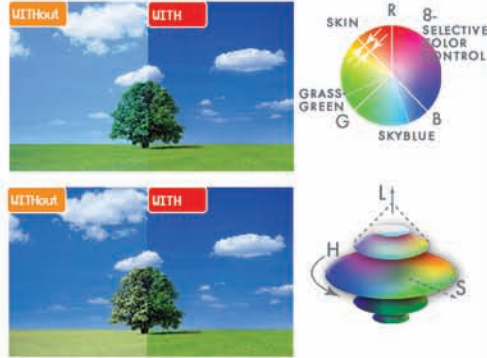

Dramatization

INTELLIGENT EDGE CONTROL

EDGE LINES ARE EMPHASIZED BY IMPROVING THE TRANSITION FROM THE BACKGROUND TO THE MAIN OBJECT.

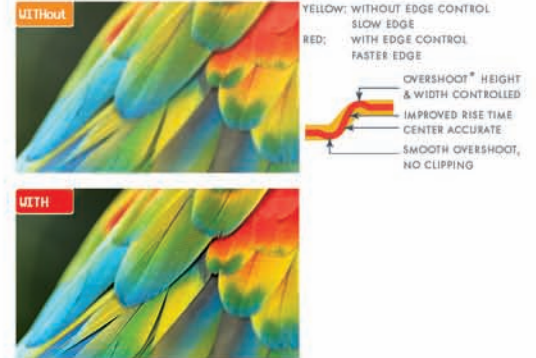

Dramatization

Pro:Idiom®

DIGITAL RIGHTS MANAGEMENT SYSTEM

The Pro:Idiom system's high-quality security unlocks access to premium content availability to help assure rapid, broad deployment of HDTV and other high value digital content. Pro:Idiom has been designed specifically for industries that use premium HDTV content from cable, satellite or video on demand (VOD) services and as such, could result in lower costs, and reduced maintenance. This system is one of the leading DRM systems embraced by content providers for both of these key programming sources. By using this embedded approach, security is provided and helps eliminate the possibility of customers tampering with or removing needed components.

MPEG-4 TECHNOLOGY

(Moving Picture Experts Group) MPEG-4 decodes and delivers high-definition programming it receives via satellite. The advanced coding system is compatible with national and local HD channels, along with digital HD channels currently launched by DIRECTV. LG built this technology into its LC50 series TVs to delivery pure HD without the need for an external box*.

* Certain functions, such as Pay-Per-View, may require a set-top box.

DIMENSIONS

42LC50C

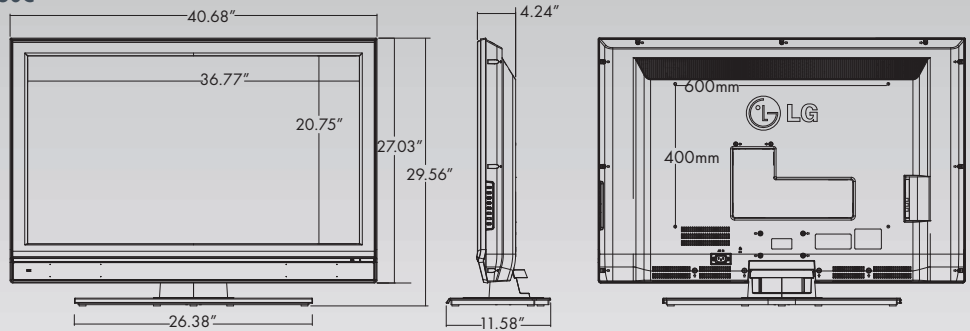

37LC50C/CB

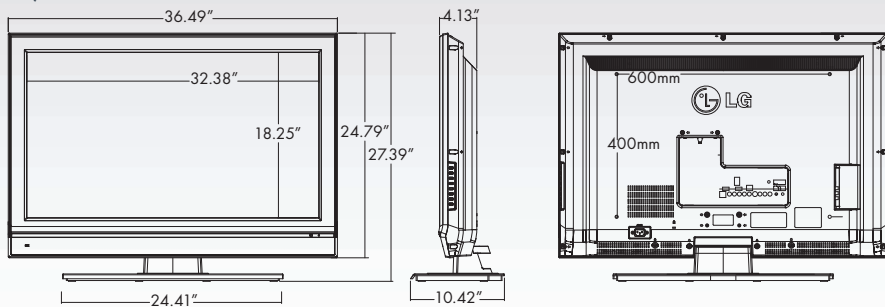

32LC50C/CB/CS

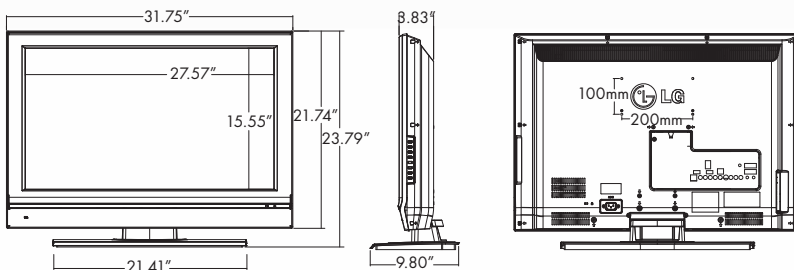

REAR JACK PANEL

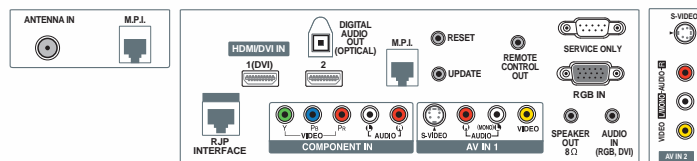

SIDE JACK PANEL



42LC50C	42" CLASS (42.0" DIAGONAL)
37LC50C	37" CLASS (37.0" DIAGONAL)
37LC50CB	
32LC50C	32" CLASS (31.5" DIAGONAL)
32LC50CB	
32LC50CS	

SPECIFICATIONS

PANEL	
LCD Panel Type	42" (42LC50C) 37" (37LC50C/CB) 32" (32LC50C/CB/CS)
Display Area	42.0" diagonal (42LC50C) 37.0" diagonal (37LC50C/CB) 31.5" diagonal (32LC50C/CB/CS)
Dynamic Contrast Ratio	12,000:1
Contrast Ratio	1600:1 (42", 37") 1500:1 (32")
Native Display Resolution	1366 x 768
Maximum Computer Resolution (RGB)	XGA (1024x768)
Brightness	500 cd/m ²
Lamp Life	60,000 hours (approx.)
Viewing Angle (HxV)	178° x 178°
Super IPS	Yes (42", 37") No (32")
Response Time	8ms (max)
VIDEO	
ATSC/NTSC/QAM Clear Tuners	Built-in
Program Guide Type	PSIP
Comb Filter	3D Digital
Color Temperature	Cool, Normal, Warm
3:2 Pull Down Cinema Correction	Yes
Aspect Ratio Adjustment	7 Modes
EZ Picture Selection Mode	5 Modes (daylight, normal, nighttime, user1, user2)
XD Engine	Yes
Blue/Black Stretcher	Yes
All Format Converter	1080i/720p/480p/480i~768p
Enhanced Video	Yes
DLTI (Digital Luminance Transient Improver)	Yes
DCTI (Digital Color Transient Improver)	Yes
Decoder Formats	MPEG-2/MPEG-4 H.264
AUDIO	
Audio Power	30W (15W x 2) - (37", 42") 20W (10W x 2) - (32")
Speaker System Details	1 Way 2 Speaker
3D EchoSound System	Yes
Dolby Digital Decoder	Yes
Bass/Treble/Balance	Yes
EZ SoundRite (Auto Volume Limiter)	Yes
EZ Sound/Sound Selection Mode	6 Modes (normal, stadium, news, music, theater, user)
Mute	Yes
Mono/Stereo/SAP	Yes
INPUTS/OUTPUTS	
RF In	1 (ATSC/NTSC)
HDMI™	Inputs 2
RGB In (PC/DTV Input)	1 (XGA Max. Resolution)
S-Video In	1 Rear/1 Side
Composite Video & Audio L/R In	1 Rear/1 Side
Digital Audio Out (Optical)	1
PC Audio In (RGB/DVI with adaptor)	1
Component HD/DVD & Audio L/R In	1
Speaker Out	1 (1 Watt, Mono)
RS-232C Input (Service Only)	1
Remote Control Out (IR)	1
RJ45 for RJP Interface	1
MPI™ (RJ11) Slot Interface	1

REQUIRED LISTINGS	
UL, c-UL, NOM	Yes
SPECIAL FEATURES	
Integrated Pro:Idiom	Yes
Calibration Mode	Yes
Function Menu	Yes
Split Screen	Yes (using optional auto-sensing jack pack)
Channel Labeling	Yes
TV Link Protocol	Yes
RJP Plug&Play Support	Yes
Discrete IR Codes	Yes
Trilingual Menus	English/Spanish/French
Sleep Timer, On/Off Timer	Yes
Flashback (Previous Channel)	Yes
Parental Control w/V-Chip	Yes
EZ Menus (High Performance Interface)	Yes
EZ Scan (Auto Channel Programming)	Yes
Closed Captions (Customizable)	Yes
Remote, Universal	Yes
CABINET	
Dimensions with Stand (W×H×D)	40.68"×29.56"×11.58" (42") 36.49"×27.39"×10.42" (37") 31.75"×23.79"×9.8" (32")
without Stand (W×H×D)	40.68"×27.03"×4.24" (42") 36.49"×24.79"×4.13" (37") 31.75"×21.74"×3.83" (32")
Packaging (W×H×D)	44.06"×33.78"×14.72" (42") 39.33"×34.53"×10.39" (37") 40.98"×25.12"×9.1" (32")
Weight with Stand	61.3 lbs (42") 47.2 lbs (37") 32.9 lbs (32")
Weight without Stand	47.2 lbs (42") 36.8 lbs (37") 26.9 lbs (32")
Weight with Packaging	71.9 lbs (42") 55.1 lbs (37") 40.8 lbs (32")
Cabinet Style	Table Top
Security Screws	Yes (attaches stand to neck)
Stand to Desk Mountable	Yes
Table Stand Included	±20° (42") ±90° (37", 32")
Power Cord Length	9 ft.
Color	Gloss Black (42LC50C, 37LC50C, 32LC50C) Matte Black (37LC50CB, 32LC50CB) Silver (37LC50CS)
VESA Standard Mount Interface	600mm x 400mm (42", 37") 200mm x 100mm (32")
UPC	
42LC50C	7 19192 17423 8
37LC50C	7 19192 17421 4
37LC50CB	7 19192 17422 1
32LC50C	7 19192 17416 0
32LC50CB	7 19192 17417 7
32LC50CS	7 19192 17418 4
POWER	
Power Consumption (typ.) with	
Power Saving Modes Disabled	215W (42"), 164W (37"), 130W (32")
Dynamic/Static Power Savings	Yes
SERVICE/LIMITED WARRANTY	
Limited Warranty (Parts/Labor)	2 Years

www.LGcommercial.com



LG Electronics U.S.A., Inc.
Commercial Products Division
2000 Millbrook Drive,
Lincolnshire, IL 60069

Customer Service: 888.865.3026

Contact your LG Regional Sales Representative:
Hospitality: 800.228.1236
B2B: 800.897.8788
Channel Markets: 800.897.8871

SPEC_42-32LC50 LGO40810_PR



All screen images are simulated. Dimensions and weights are approximate. Design, features and specifications subject to change without notice.

© Copyright 2008 LG Electronics USA, Inc. All Rights Reserved. "LG Life's Good" is a registered trademark of LG Corp. XD Engine is a registered trademark of LG Electronics USA, Inc. Pro:Idiom and MPI are trademarks of Zenith Electronics Corp.

VESA is a trademark of Video Electronics Standards Association. HDMI, the HDMI Logo and High-Definition Multimedia Interface are trademarks or registered trademarks of HDMI Licensing LLC. Dolby and the double-D symbol are registered trademarks of Dolby Laboratories. All other product and brand names are trademarks or registered trademarks of their respective companies.

Printed in the USA. August 2008